

## HM: Secondary Air Injection (AIR) System Introduction

[HM: Pinpoint Tests](#) →

This pinpoint test is intended to diagnose the following:

- secondary air injection system relay (14B192)
  - electric air injection pump (9A486)
  - secondary air injection bypass solenoid (9H465)
  - harness circuits: B+, VPWR, AIR, AIRM and ground
  - powertrain control module (PCM) (12A650)
- 
- secondary air injection diverter valve (9F491)
  - vacuum supply
  - hoses
  - partial restricted exhaust

Refer to the Wiring Diagrams Manual for schematic and connector information.

### Secondary AIR Relay Connector

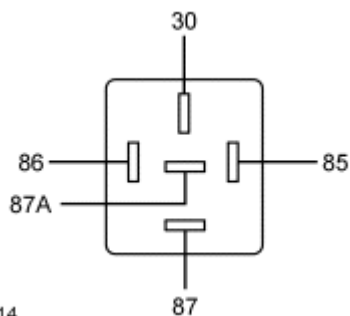

Pin	Circuit
86	AIR (Secondary Air Injection)
87	AIR_PWR (AIR Pump Power)
30	B+ (Battery Positive Voltage)
85	VPWR (Vehicle Power)

### Secondary Air Pump Connector

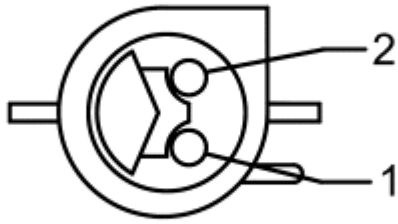

A0077529

Pin	Circuit
2	AIR_PWR (AIR Pump Power)
1	AIR_GND (AIR Pump Ground)

### Powertrain Control Module (PCM) Connector

For PCM connector views or reference values, refer to [Section 6](#).

Connector	Pin	Circuit
140 Pin	B58	SIGRTN CASE GND
	B66	PWRGND
	B67	VREF VPWR
	B33	AIRM AIR
	B51	
	B50	
	B1	